

APPROVED: _____
 DATE: _____ TITLE: _____

Rev	AWO #	Description	Date	Appr
-		RELEASED	01/06/12	

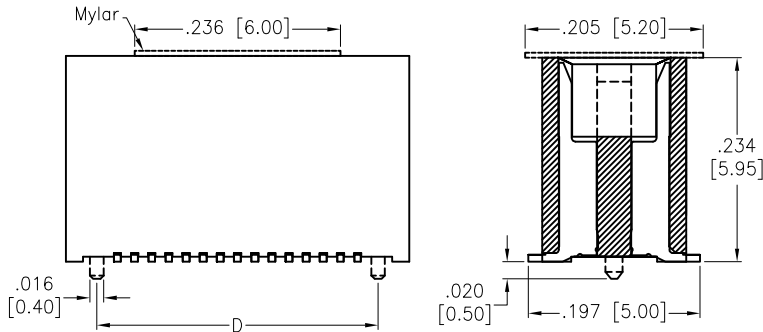
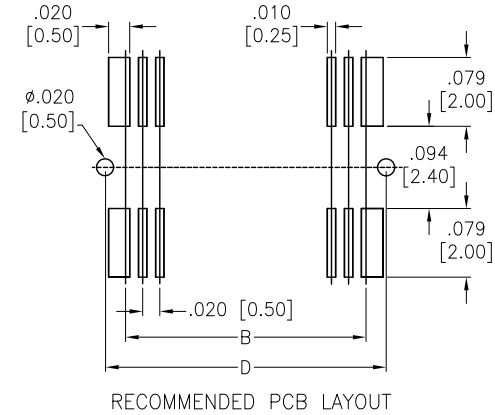
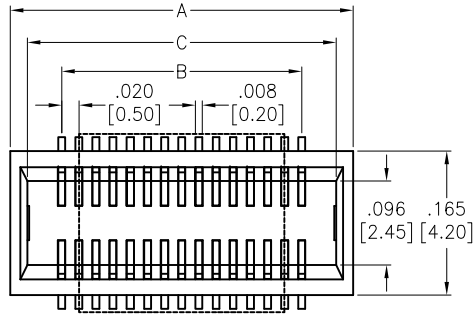

SPECIFICATIONS:

Material:
 Insulator: Nylon9T, rated UL 94V-0
 Insulator color: White
 Contacts: Phosphor Bronze
 Plating:
 Gold flash over Nickel underplate overall
 Electrical:
 Operating voltage: 50 VAC max.
 Current rating: 0.3 Amps max.
 Contact resistance: 60 mohms max. initial
 Insulation resistance: 100 Mohms min.
 Dielectric withstanding voltage: 500 VAC for 1 minute
 Environmental:
 Lead free, RoHS compliant
 Recommended soldering temp: 260°C for 5 seconds



Positions: 10 Thru 120

A = .020 [0.50] x Spaces per row + .118 [3.00]
 B = .020 [0.50] x Spaces per row
 C = .020 [0.50] x Spaces per row + .079 [2.00]
 D = B + .047 [1.20]

UNLESS OTHERWISE SPECIFIED ALL DIMENSIONS ARE INCHES [MM] TOLERANCES: EXCEPT AS NOTED			
INCHES		HOLES	
.X	± .10	Ø.X	± .10
.XX	± .020	Ø.XX	± .015
.XXX	± .015	Ø.XXX	± .010



APPROVALS		DATE
DRAWN	TW	01/06/12
CHECKED	AY	01/06/12
APPROVED		

TITLE .020 [0.50] BOARD TO BOARD SOCKET 5.95MM HEIGHT, SMT TYPE, MYLAR		
SIZE X	PART NO. BB5-SM1-XXX-G-5.95-KT-T/R	REV. -
REF: S00206T	SCALE: NTS	SHEET 1 OF 1