

APPROVED: _____

DATE: _____ TITLE: _____

Rev	AWO #	Description	Date	Appr
-		RELEASED	10/8/24	

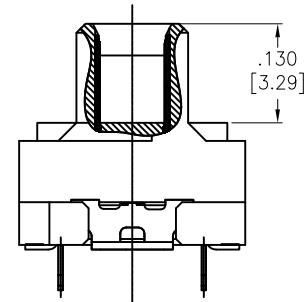
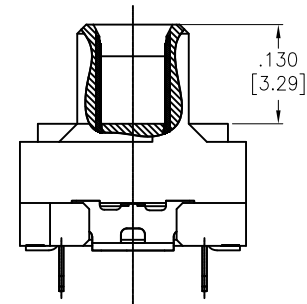
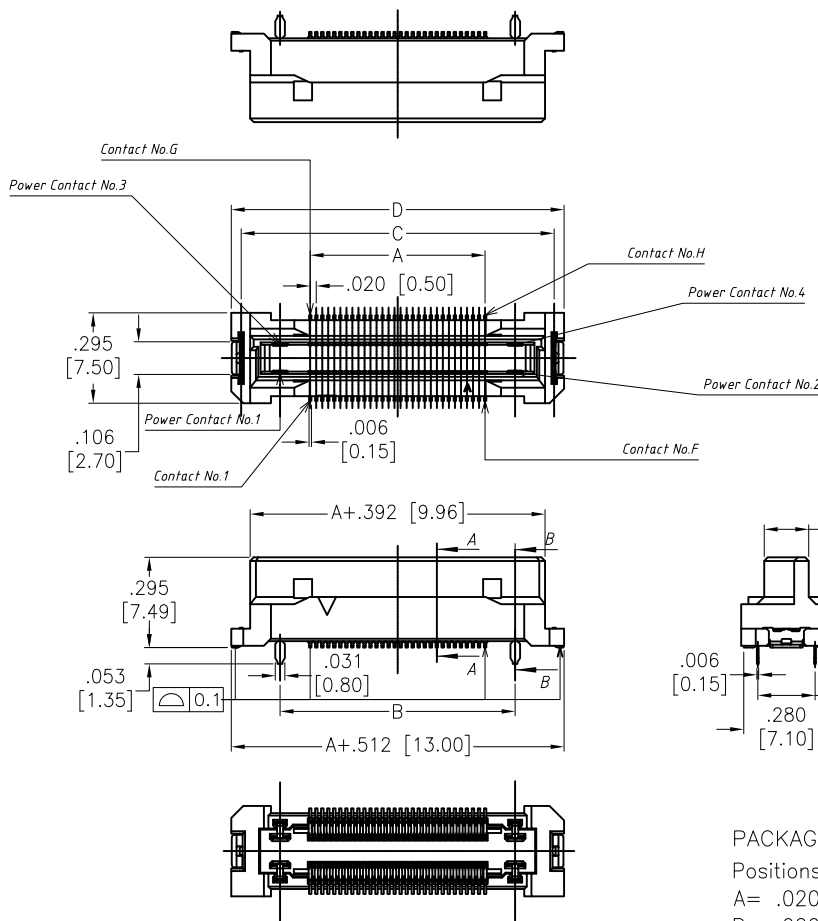

PACKAGED ON TAPE & REEL
 Positions: 20, 30, 30, 40, 50, 60, 80, 100, 120
 A= .020 [0.50] x No. of Space
 B= .020 [0.50] x No. of Space + .197 [5.00]
 C= .020 [0.50] x No. of Space + .451 [11.45]
 D= .020 [0.50] x No. of Space + .516 [13.10]
 E= .020 [0.50] x No. of Space + .506 [12.86]

SPECIFICATIONS:

Material:
 Insulator: Polyamide, rated UL 94V-0
 Insulator color: Black
 Cap: Polyamide, rated UL 94V-0, Color: Black
 Signal Contacts: Copper Alloy
 Power Contacts: Copper Alloy
 Hook: Copper Alloy, Tin Plated
 Plating:
 Gold Flash over Nickel underplate on contact area,
 Tin over Nickel underplate on solder tails
 Environmental:
 Lead free, RoHS compliant.



UNLESS OTHERWISE SPECIFIED ALL DIMENSIONS ARE INCHES [MM]. TOLERANCES: EXCEPT AS NOTED

INCHES		HOLES	
.X	± .10	ØX	±.10
.XX	± .020	ØXX	±.015
.XXX	± .015	ØXXX	±.010



DRAWN	LH	10/8/24
CHECKED	JL	10/8/24
APPROVED		
THIS DRAWING CONTAINS INFORMATION THAT IS PROPRIETARY AND SHOULD NOT BE USED WITHOUT PRIOR WRITTEN PERMISSION FROM ADAM TECH		

TITLE .020 [0.50] PITCH BOARD TO BOARD PLUG I/O SMT FLOATING CONNECTOR		
SIZE X	PART NO. BB5-FPW-XXX-SG-7.49-PP-T/R	REV. -
REF: -	SCALE: NTS	SHEET 1 OF 2

6

5

4

3

2

1

APPROVED: _____

DATE: _____ TITLE: _____

Rev	AWO #	Description	Date	Appr
SEE SHT 1 OF 2 FOR REVISION				

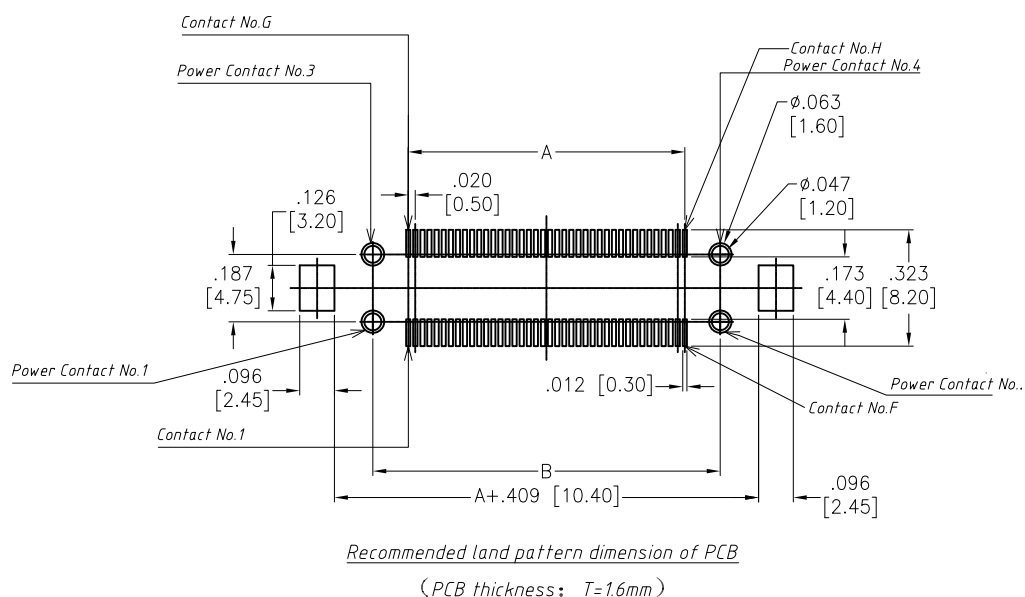
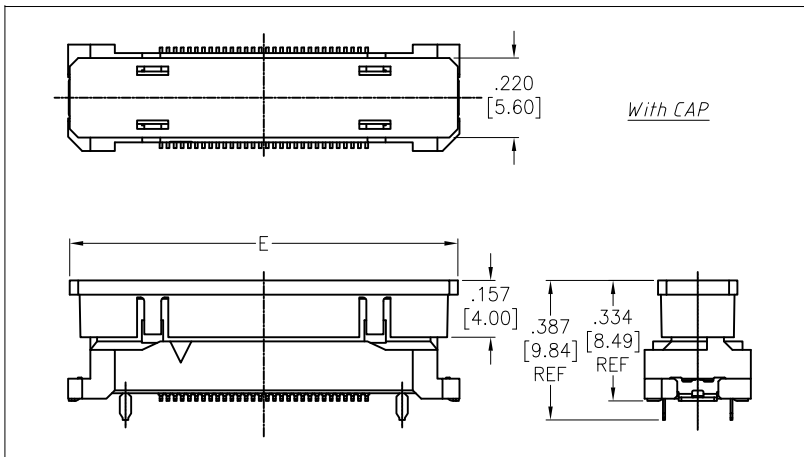

UNLESS OTHERWISE SPECIFIED ALL DIMENSIONS ARE INCHES [MM]. TOLERANCES: EXCEPT AS NOTED

INCHES		HOLES	
.X	± .10	ØX	±.10
.XX	± .020	ØXX	±.015
.XXX	± .015	ØXXX	±.010

ADAM TECH
 909 Rahway Avenue,
 Union, NJ 07083
 Phone: 908-687-5000
 Fax: 908-687-5710

DRAWN	LH	10/8/24
CHECKED	JL	10/8/24
APPROVED		
THIS DRAWING CONTAINS INFORMATION THAT IS PROPRIETARY AND SHOULD NOT BE USED WITHOUT PRIOR WRITTEN PERMISSION FROM ADAM TECH		

TITLE .020 [0.50] PITCH BOARD TO BOARD PLUG I/O SMT FLOATING CONNECTOR		
SIZE X	PART NO. BB5-FPW-XXX-SG-7.49-PP-T/R	REV. -
REF: -	SCALE: NTS	SHEET 2 OF 2

6

5

4

3

2

1